



CPD20L1S

Electric Forklift 2.0T

- Performance improvement of AC motor
- Strength improvement of new mast
- Safety improvement of mechanical braking
- Large battery capacity

EP EQUIPMENT CO.,LTD
www.ep-ep.com

FEATURE

■ Performance improvement of AC motor

All the motors are AC and they provide higher performance.



■ Strength improvement of new mast

CJ mast is applied in this truck thus it is more solid and durable. Moreover, using CJ mast can offer wider view for the driver.

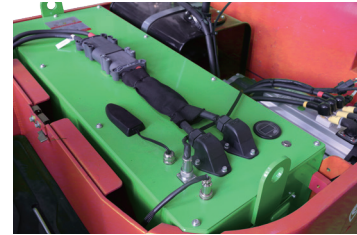

■ Safety improvement of mechanical braking

The truck uses mechanical braking and its braking distance is shorter.



■ Large battery capacity

It is equipped with Li-ion battery and is suitable for high frequency use.



Electric Forklift 2.0T

CPD20L1S

Distinguishing mark				
1.1	Manufacturer			EP
1.2	Model designation			CPD20L1-S
1.3	Drive unit			Electrics
1.4	Operator type			seated
1.5	rated capacity	Q	t	2
1.6	Load center distance	c	mm	500
1.8	Load distance, centre of drive axle to fork	x	mm	435
1.9	Wheelbase	y	mm	1470
Weight				
2.1	Service weight (include battery)		kg	3280
2.2	Axle loading, laden driving wheels /steering wheels		kg	4512/768
2.3	Axle loading, unladen driving wheels /steering wheels		kg	1240/2040
Types,Chassis				
3.1	Tyre type,driving wheels /steering wheels			solid rubber
3.2	Tyre size, driving wheels			200/50-10
3.3	Tyre size, steering wheels			5.00-8
3.5	Wheels, number driving/steering (x=drive wheels)		mm	2x/ 2
3.6	Tread, Driving wheels	b ₁₀	mm	942
3.7	Tread, Steering wheels	b ₁₁	mm	920
Dimensions				
4.1	Tilt of mast/fork carriage forward/backward	α/ β (°)		6/ 11
4.2	Height, mast lowered	h ₁	mm	2080
4.3	Free lift (load backrest)	h ₂	mm	105
4.4	Lift height	h ₃	mm	3000
4.5	Height, mast extended	h ₄	mm	4028
4.7	Height of overhead guard (cabin)	h ₆	mm	2080
4.8	Seat height	h ₇	mm	1050
4.12	Tow center of pin height	h ₁₀	mm	360
4.19	Overall length	l ₁	mm	3315
4.20	Length to face of forks	l ₂	mm	2245
4.21	Overall width	b ₁ / b ₂	mm	1130
4.22	Fork dimensions	s/ e/ l	mm	40×100×1070
4.23	Fork carriage class/type A, B			2A
4.24	Fork carriage width	b ₃	mm	1040
4.31	Ground clearance, laden, below mast	m ₁	mm	110
4.32	The minimum ground clearance of frame	m ₂	mm	105
4.34.1	Aisle width for pallets 1000 × 1200 crossways	Ast	mm	3685
4.34.2	Aisle width for pallets 800 × 1200 lengthways	Ast	mm	3885
4.35	Turning radius	Wa	mm	2080
Performance data				
5.1	Travel speed, laden/ unladen		km/ h	15/16
5.2	Lifting speed, laden/ unladen		m/ s	0.33/0.48
5.3	Lowering speed, laden/ unladen		m/ s	0.42/ 0.45
5.5	Drawbar pull, laden/unladen		N	—
5.6	Max. drawbar pull, laden/unladen (time)		N	—
5.7	Gradeability, laden/unladen		%	—
5.8	Max. gradeability, laden/unladen		%	16/20
5.10	Service brake type			Hydraulic / Mechanical
	park brake type			Mechanical
Electric-engine				
6.1	Drive motor rating S2 60 min		kW	7
6.2	Lift motor rating at S3 15%		kW	11
6.3	The maximum allowed size battery		mm	930X340X595
6.4	Battery voltage/nominal capacity K5		V/AH	48V360AH
6.5	Battery weight		kg	220
Addition data				
8.1	Type of drive unit			AC
10.5	Steering type			Hydraulic steering
10.7	Sound pressure level at the driver's ear		dB (A)	73

If there are improvements of technical parameters or configurations, no further notice will be given.

The diagram shown may contain non-standard configurations.

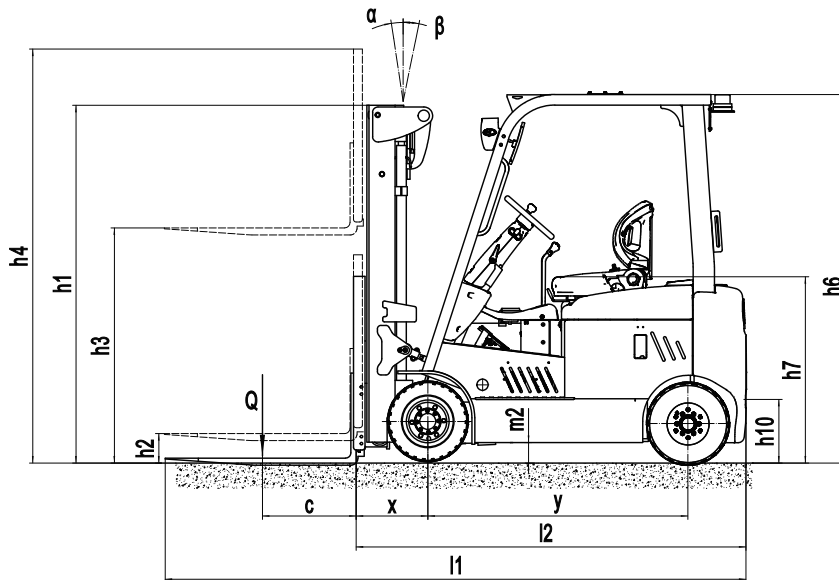
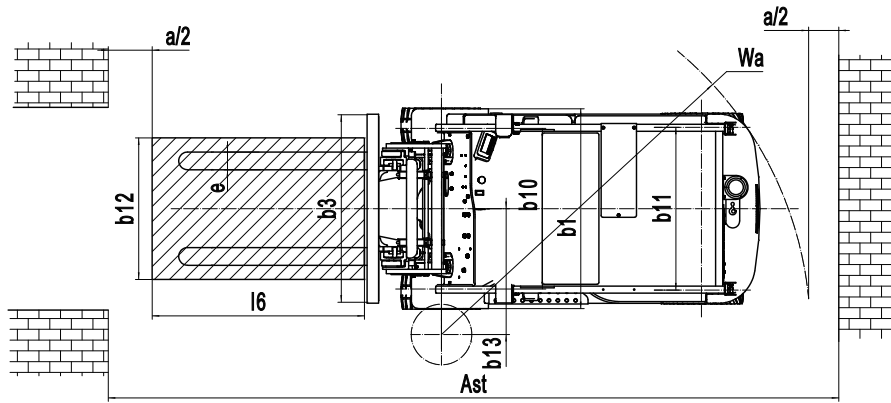

Mast option:

Type	Model	Max. fork height h3 mm	Overall height			Free lift		Front Overhang X mm	Tilt range		Capacity
			Lowered h1 mm	Extended		Without backrest mm	With backrest h2 mm		FWD α Deg	BWD β Deg	Load capacity at 500 mm
				Without backrest mm	With backrest h4 mm						Single tire 2t
Wide view mast	2W200	2000	1515	2485	3028	120	120	435	6	11	2000
	2W250	2500	1765	2985	3528	120	120	435	6	11	2000
	2W270	2700	1865	3185	3728	120	120	435	6	11	2000
	2W300	3000	2015	3485	4028	120	120	435	6	11	2000
	2W330	3300	2165	3785	4328	120	120	435	6	11	2000
	2W350	3500	2265	3985	4528	120	120	435	6	11	2000
	2W360	3600	2315	4085	4628	120	120	435	6	11	2000
	2W400	4000	2565	4485	5028	120	120	435	3	6	1900
	2W430	4300	2715	4785	5328	120	120	435	3	6	1800
2W450	4500	2815	4985	5528	120	120	435	3	6	1600	
wide view full 2-stage mast	2F250	2500	1798	2985	3528	1313	770	435	6	10	2000
	2F270	2700	1898	3185	3728	1413	870	435	6	10	2000
	2F300	3000	2048	3485	4028	1563	1020	435	6	10	2000
	2F330	3300	2198	3785	4328	1713	1170	435	6	10	2000
	2F360	3600	2348	4085	4628	1863	1320	435	6	10	2000
2F400	4000	2548	4485	5028	2063	1520	435	6	10	1850	
wide view full 3-stage mast	3F435	4350	2030	4844	5378	1536	1002	447.5	6	6	1750
	3F450	4500	2080	4994	5528	1586	1052	447.5	6	6	1650
	3F480	4800	2180	5294	5828	1686	1152	447.5	6	6	1450
	3F500	5000	2245	5494	6028	1751	1217	447.5	6	6	1350
	3F550	5500	2415	6010	6510	1905	1405	447.5	3	3	1000
	3F600	6000	2630	6510	7010	2120	1620	447.5	3	3	600

RATED CAPACITIES AND LOAD CENTERES GRAPH

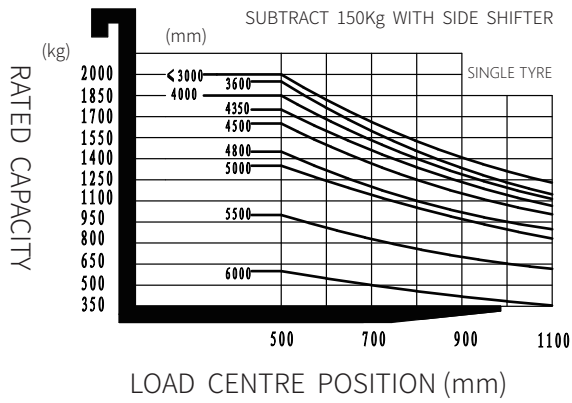

Option:

	Optional items	CPD20L1S
1	Fork length	○
2	Folding fork	○
3	Battery capacity	○
4	Import battery	—
5	Solid rubber tire	●
6	Environmental solid tire	○
7	cold storage	—
8	Lateral change battery	—
9	Weighting system with fork	○
10	Overhead guard	○
11	Mast options	○
12	Attachments	○
13	Side shift	○
14	Proportional valve	—
17	Front light	●
28	Back light	○
22	Warning light	●
18	Fire extinguisher	○
19	Water auto-filling system	—
20	Seat	○
21	Seat switch	○
23	With fan heater	○
25	With front windshield wiper	○
26	With rear windshield wiper	○
16	Cockpit	○
24	Doulbe front wheel	—
27	Rearview	●
29	OPS system	○
30	Backrest width	○
31	Side to pull the car	—
32	Air fan	○
33	Charging voltage (220V)	○
35	Drive-in Rack	○

Note: ● standard ○ option — NA